

Pre-assembled all metal hammer set through fixing.



Fast all metal hammer fixing

Substrates

- Concrete
- Stone

Applications

- Suspended ceiling brackets
- Trunking
- Signs
- Drywall track and brackets
- Brick ties

Product Advantages

- **Visible proof the anchor is fully set**
- When the head of the nail sits flush with the top of the anchor
- **Quick through fixing**
- **Positive expansion by nail**
- **Large flange** - Prevents pullover
- **Relatively resistant to vandalism**

Technical Specification

An expansion anchor set by hammering in of an internal expansion nail.

Material

Expansion nail - Hardened Steel
Sleeve CL35 - Zinc Coated Steel
Sleeve Shuredrive - Zinc Alloy

Installation

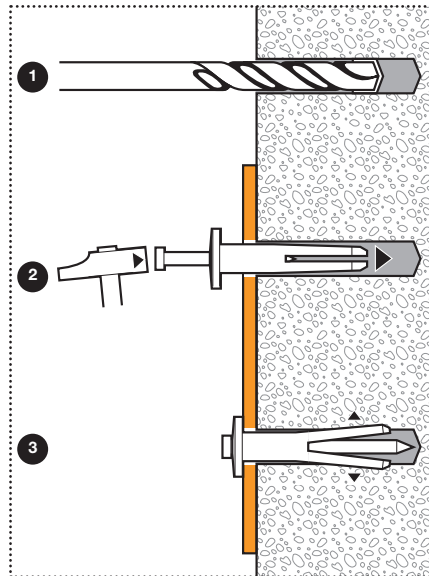

Product Range - Atlas CL35 Steel Hammer-in Anchor

	Eurocode	Anchor Ø	Overall Anchor Length	Flange Head	Max Fixture Thickness	Min Hole Depth	Box Qty
	056990	6.0mm	36mm	11mm	5mm	35mm	100

Product Range - Shuredrive Alloy Hammer-in Anchor

	Eurocode	Anchor Ø	Overall Anchor Length	Flange Head	Max Fixture Thickness	Min Hole Depth	Box Qty
	920869	6mm	40mm	13mm	18mm	22mm	100
	920870	6mm	50mm	13mm	28mm	22mm	100