

Beyond Clarity

1.3M HD Network Camera



1.3Megapixel HD Network Vandal-Resistant Flat Camera

SNV-5010

The SNV-5010, is a high performance megapixel network camera, generates images at multiple resolution, from CIF to 16 : 9 HD and 1.3 megapixels. And, images look much bigger, wider and clearer at the HD and 1.3 megapixels resolution. In addition, the SNV-5010 supports H.264 / MPEG-4 / JPEG multiple codec to achieve both a real time monitoring and high quality recording. The SNV-5010 is compact and fit enough to be held in one hand and its stylish design blends into any environment.

- Max. 1.3M (1280 x 1024) resolution
- 16 : 9 HD (720p) resolution support
- Built-in 3mm fixed lens
- H.264 / MPEG-4 / MJPEG multiple codec
- PoE, IP66

1.3Megapixel HD Network Vandal-Resistant Flat Camera

SNV-5010



Specifications



	SND-1010N	SND-1010P
VIDEO		
Imaging Device	1/3" 1.3M PS CMOS	
Total Pixels	1,384(H) x 1,076(V)	
Effective Pixels	1,329(H) x 1,049(V)	
Scanning System	Progressive	
Min. Illumination	Color : 1Lux (F1.8, 50IRE), 0.016Lux (Sens-up 60x)	
S / N Ratio	50dB	
Video Output	DIP connector	
LENS		
Focal Length (Zoom Ratio)	3mm	
Max. Aperture Ratio	F1.8	
Angular Field of View	H : 91.2°, V : 72.3°	
Lens Type	Fixed iris	
Mount Type	Board type	
PAN / TILT / ROTATE		
Pan Range	-10° ~ 10°	
Tilt Range	0° ~ 90°	
OPERATIONAL		
On Screen Display	English, French, German, Spanish, Italian, Chinese, Korean, Russian, Japanese, Swedish, Danish, Portuguese	
Camera Title	Off / On (Displayed up to 15 characters)	
Backlight Compensation	Off / BLC / HLC	
Contrast Enhancement	SSDR (Samsung Super Dynamic Range) (Off / On)	
Digital Noise Reduction	SSNRll (2D+3D noise filter) (Off / On)	
Privacy Masking	Off / On (12 Programmable zones)	
Sens-up (Frame Integration)	Off / Auto (2x ~ 60x)	
Gain Control	Off / Low / Medium / High / Manual	
White Balance	ATW / AWC / Manual / Indoor / Outdoor	
Electronic Shutter Speed	Auto / A.FLK / Manual (1/30 ~ 30,000sec)	
Flip / Mirror	Off / On	
Intelligent Video Analytics	Scene change, Virtual line, Enter / Exit, Appear / Disappear	
NETWORK		
Ethernet	RJ-45 (10/100BASE-T)	
Video Compression Format	H.264, MPEG-4, MJPEG	
Resolution	1280 x 1024, 1280 x 720P (HD), 800 x 600, 640 x 480, 320 x 240	
Max. Framerate	22fps (1280 x 1024), 30fps (720P HD)	
Video Quality Adjustment	H.264 / MPEG-4 : Compression level, Target bitrate level control MJPEG : Quality level control	
Bitrate Control Method	H.264 / MPEG-4 : CBR or VBR, MJPEG : VBR	
Streaming Capability	Multiple streaming (Up to 10 profiles)	
IP	IPv4, IPv6	
Protocol	TCP/IP, UDP/IP, RTP(UDP), RTP(TCP), RTSP, NTP, HTTP, HTTPS, SSL, DHCP, PPPoE FTP, SMTP, ICMP, IGMP, SNMPv1/v2c/v3(MIB-2), ARP, DNS, DDNS	
Security	HTTPS(SSL) login authentication, Digest login authentication IP address filtering, User access log	
Streaming Method	Unicast / Multicast	
Max. User Access	10 users at unicast mode	
ONVIF Conformance	Yes	
Web Viewer	Supported OS : Windows XP / VISTA / 7, MAC OS Supported Browser : Internet Explorer 6.0 or Higher, Firefox, Google Chrome, Apple Safari	
Central Management Software	NET-V viewer	
ENVIRONMENTAL		
Operating Temperature / Humidity	-10°C ~ +50°C (-14°F ~ +122°F) / 20% ~ 80% RH	
Ingress Protection	IP66 Grade (Waterproof)	
ELECTRICAL		
Input Voltage / Current	12V DC, PoE (IEEE802.3af)	
Power Consumption	Max. 6W	
MECHANICAL		
Color / Material	Ivory / Aluminum	
Dimensions (WxHxD)	125.2 x 52 x 115.2mm (4.93" x 2.05" x 4.54")	
Weight	430g (0.95 lb)	

Dimensions

Unit : mm (inch)

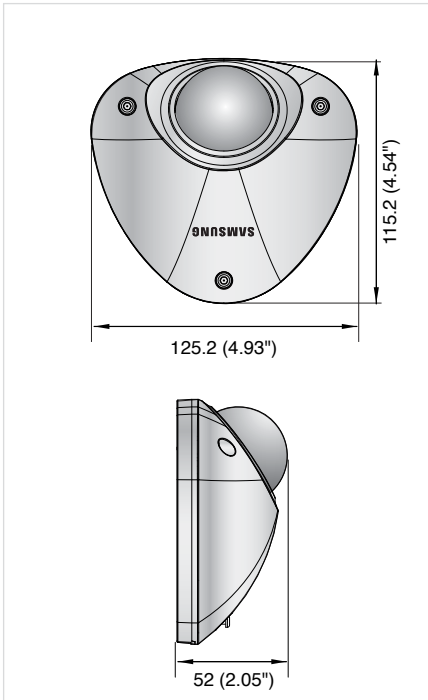

The Eco mark represents Samsung Techwin's will to create environment-friendly products, and indicates that the product satisfies the EU RoHS Directive.

Design and specifications are subject to change without notice.



SAMSUNG TECHWIN CO., LTD.

701, Sampyeong-dong, Bundang-gu, Seongnam-si, Gyeonggi-do Korea 463-400
Tel : +82-70-7147-8741~8749, 8752-8760 Fax : +82-31-8018-3745
www.samsungipolis.com www.samsungsecurity.com

SAMSUNG TECHWIN AMERICA INC.
1480 Charles Willard St. Carson, CA 90746, UNITED STATES
Tel Free : +1-877-213-1222 Fax : +1-310-632-2195
www.samsungcctvusa.com

SAMSUNG TECHWIN EUROPE LTD.
Samsung House, 1000 Hillswood Drive, Hillswood Business Park
Chertsey, Surrey, UNITED KINGDOM KT16 0PS
Tel : +44-1932-45-5300 Fax : +44-1932-45-5325

TIANJIN SAMSUNG TECHWIN OPTO-ELECTRONICS CO., LTD.
No.11 Wei 6 Street, Micro-Electronic Industrial Park
Jingang Road, Tianjin, P.R. CHINA 300385
Tel : +86-22-23887788 Fax : +86-22-23887788

■ DISTRIBUTED BY



www.use-ip.co.uk
01304 827609